

CAUTION!

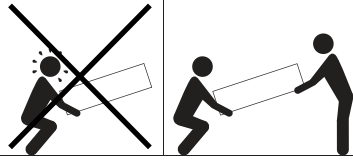

min. 2 persons needed during installation

Installation Instruction

SUPERNOVA LINE 6583 DIM1

DEEL
PARTIE
TEIL
PART
PARTE
PARTE

A

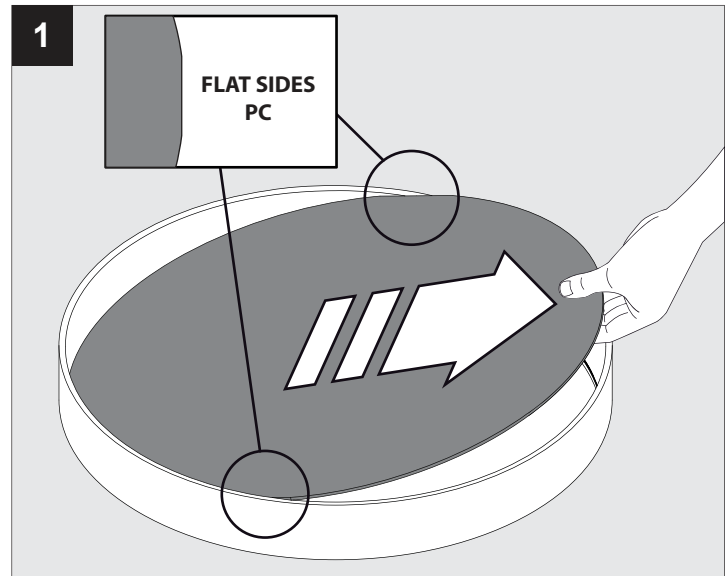
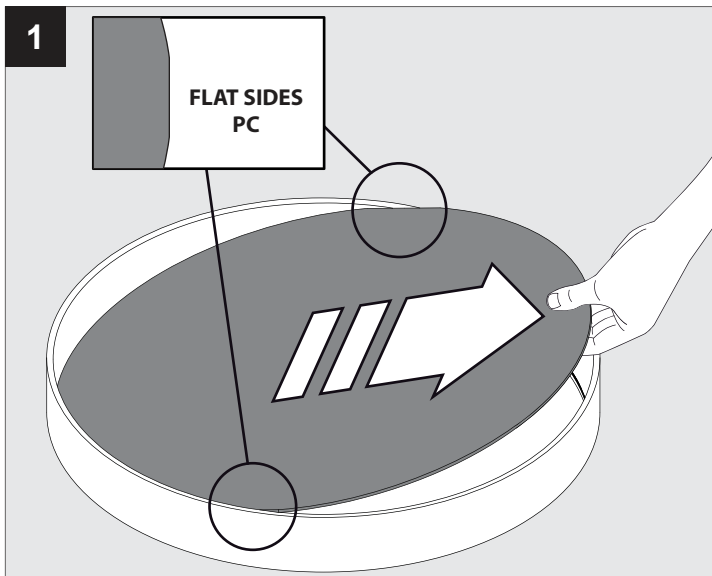
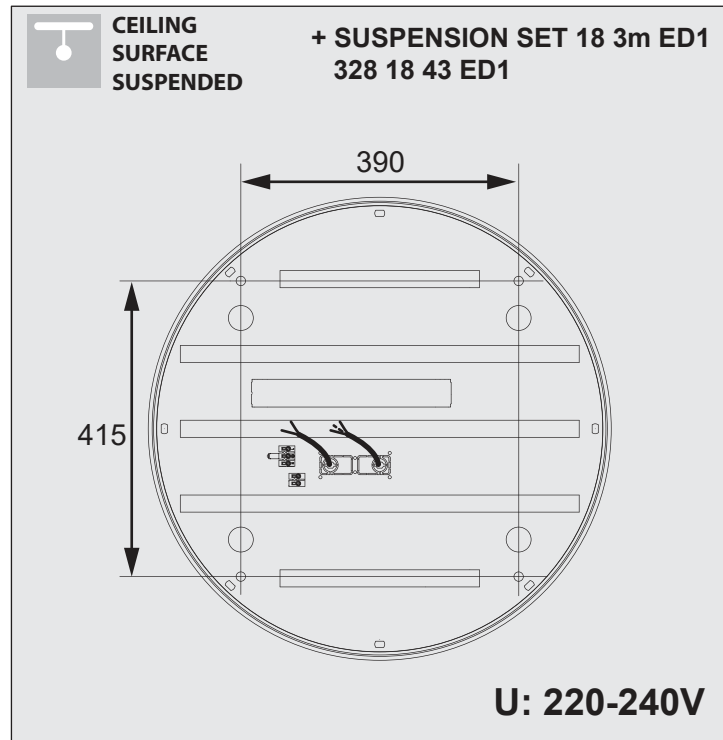
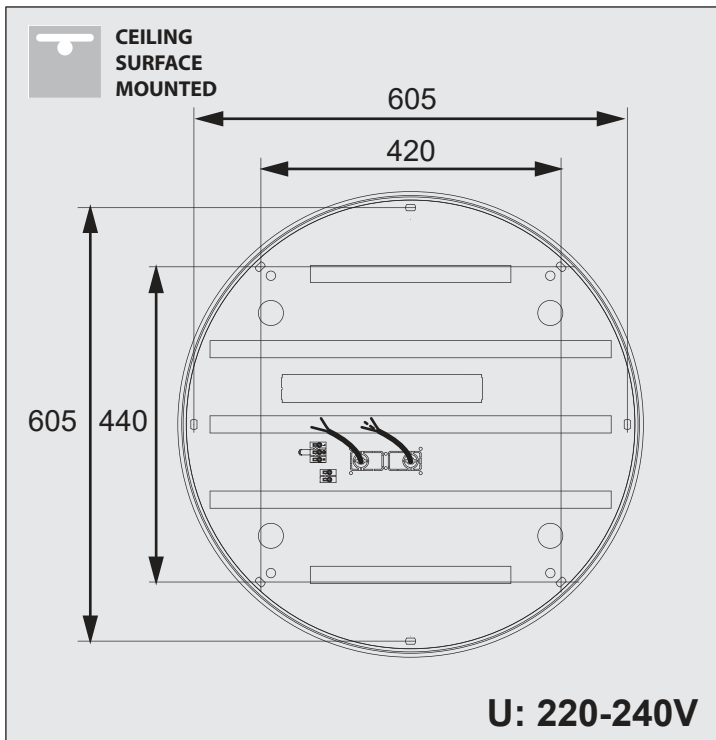
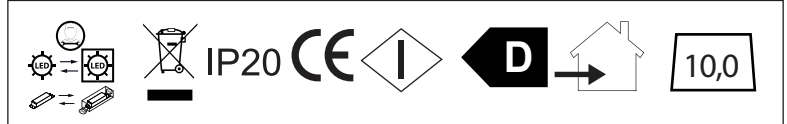
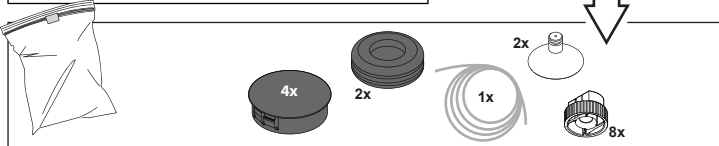
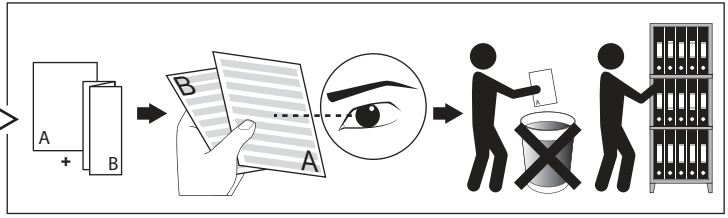
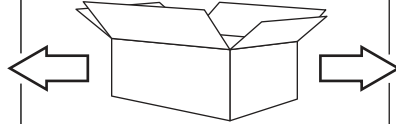
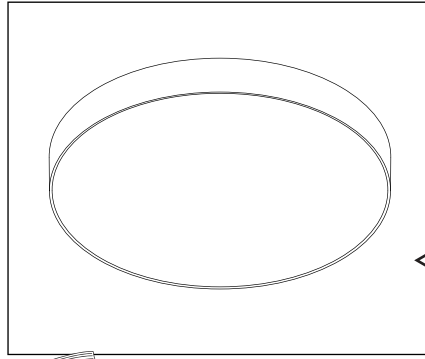

CEILING SURFACE MOUNTED

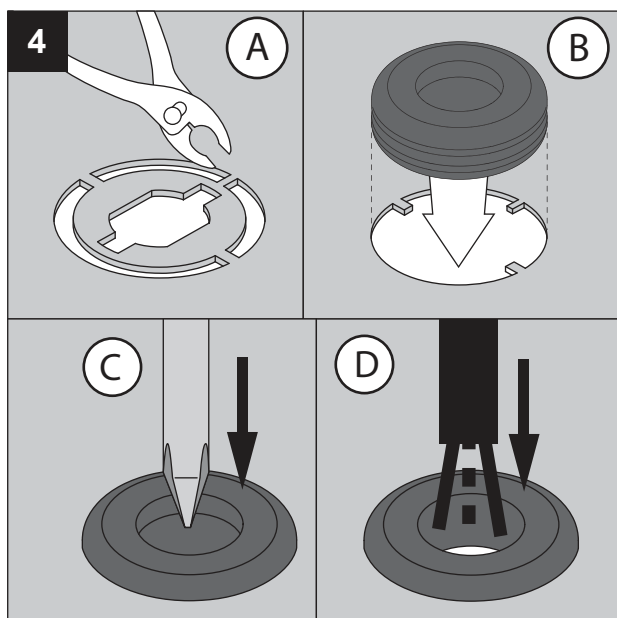
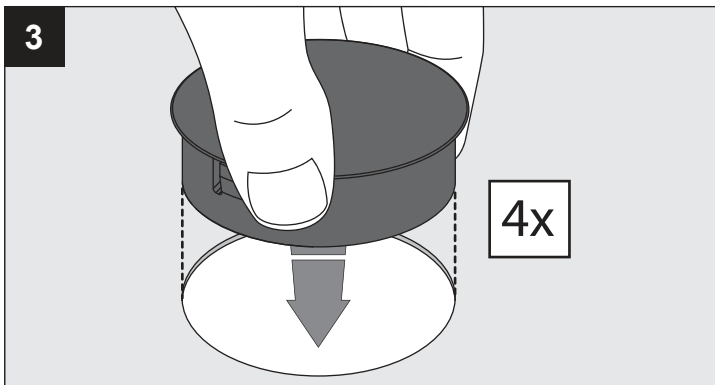
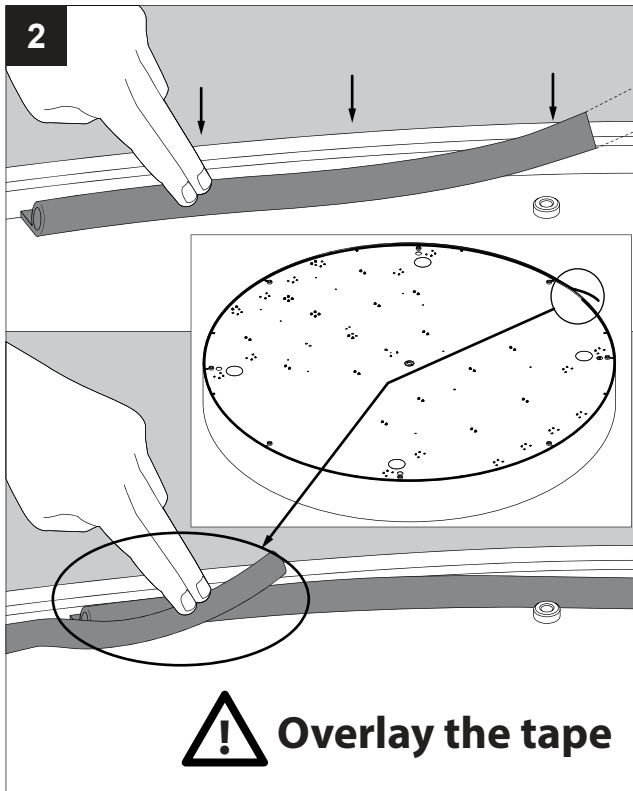

CEILING SURFACE SUSPENDED

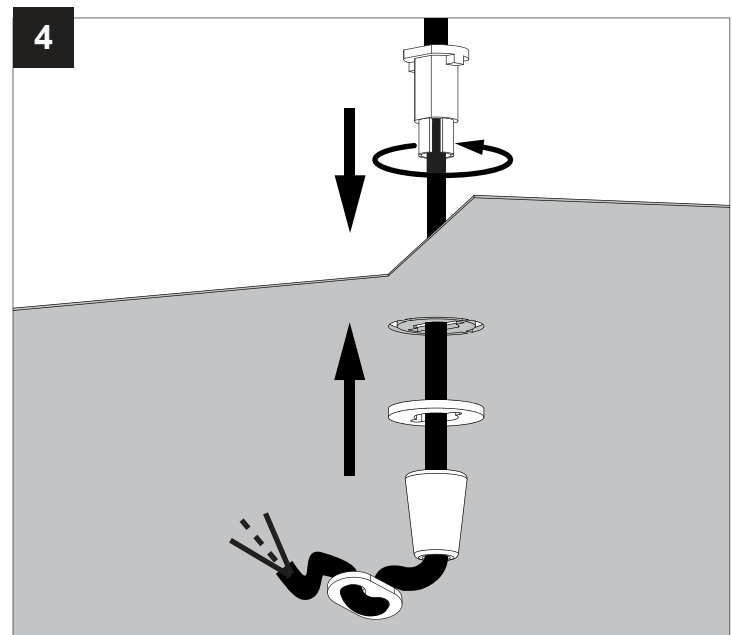
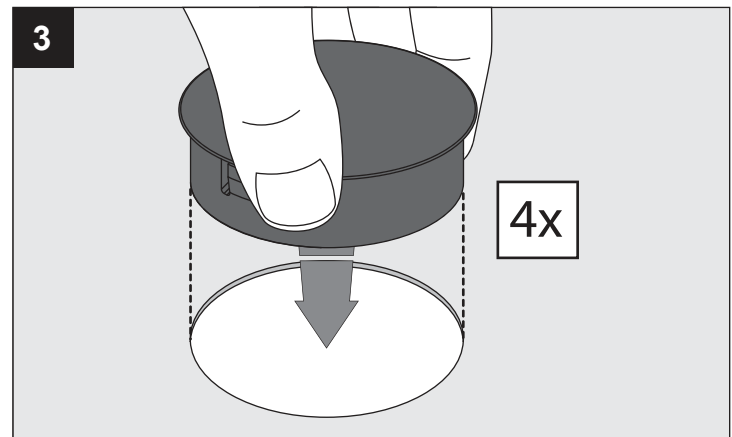
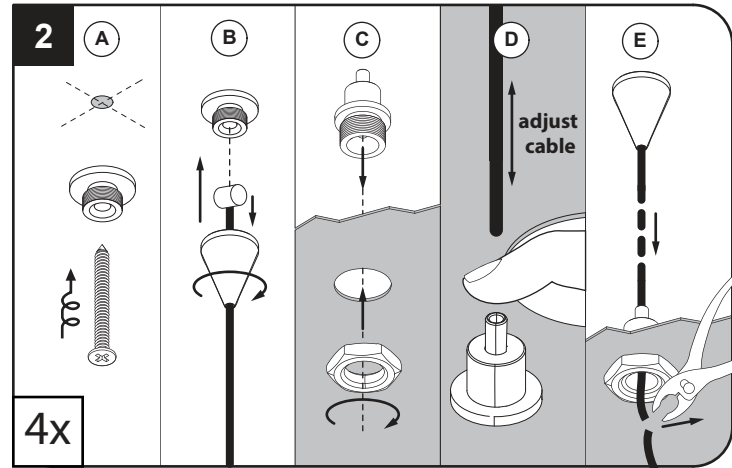

CEILING SURFACE MOUNTED

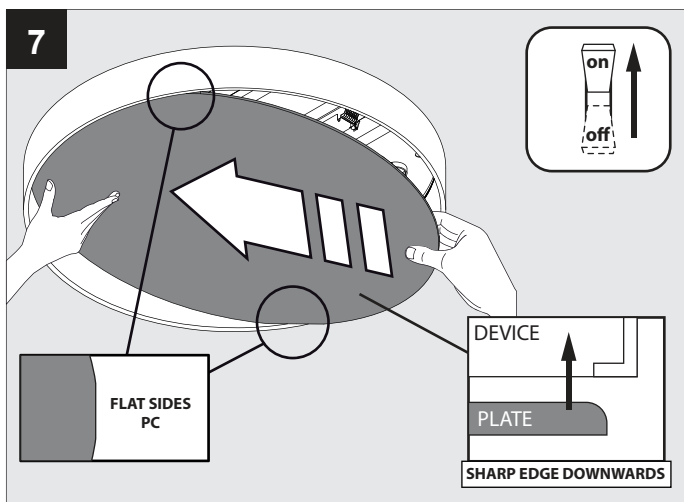
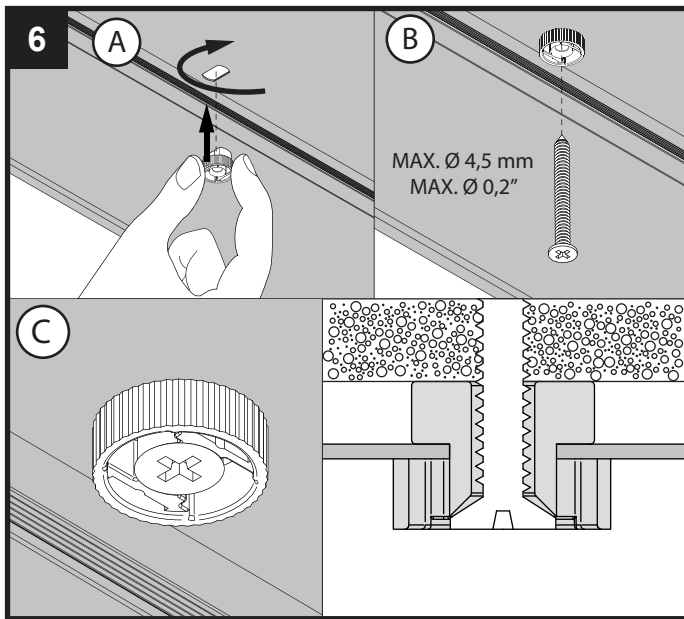
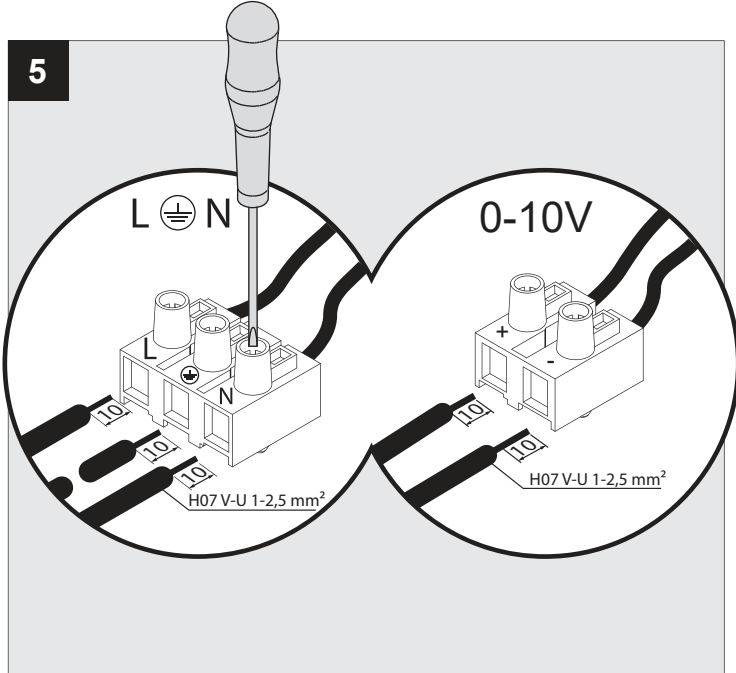

CEILING SURFACE SUSPENDED

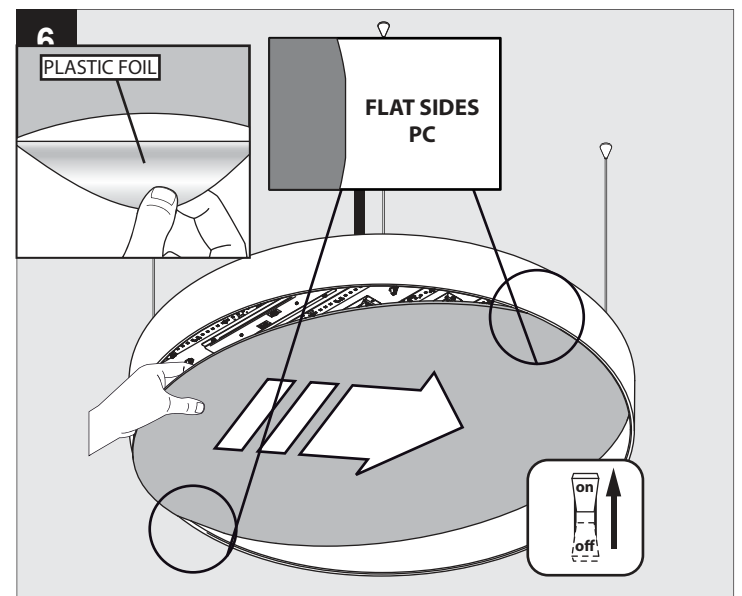
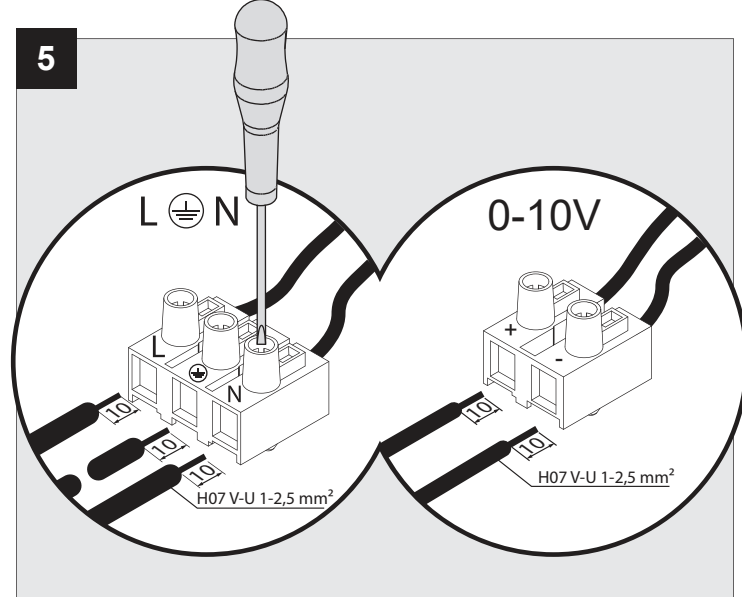

De verlichtingsbron van dit verlichtingstoestel zal enkel door de fabrikant of door de fabrikant aangestelde installateur vervangen worden.

La source lumière de cet appareil ne sera remplacée que par l'entrepreneur ou par un agent reconnu.

Das enthaltene Leuchtmittel sollte nur durch entsprechendes Fachpersonal ersetzt werden.

The light source contained in this luminaire shall only be replaced by the manufacturer or his service agent.

La fuente de iluminación que tiene esta luminaria sólo puede remplazarse por el fabricante o por un instalador autorizado.

La sorgente luminosa incorporata in questo apparecchio può essere sostituita solo dal produttore, da un suo centro assistenza oppure da una persona in possesso della necessaria abilitazione.

HOW TO REMOVE THE LENS?

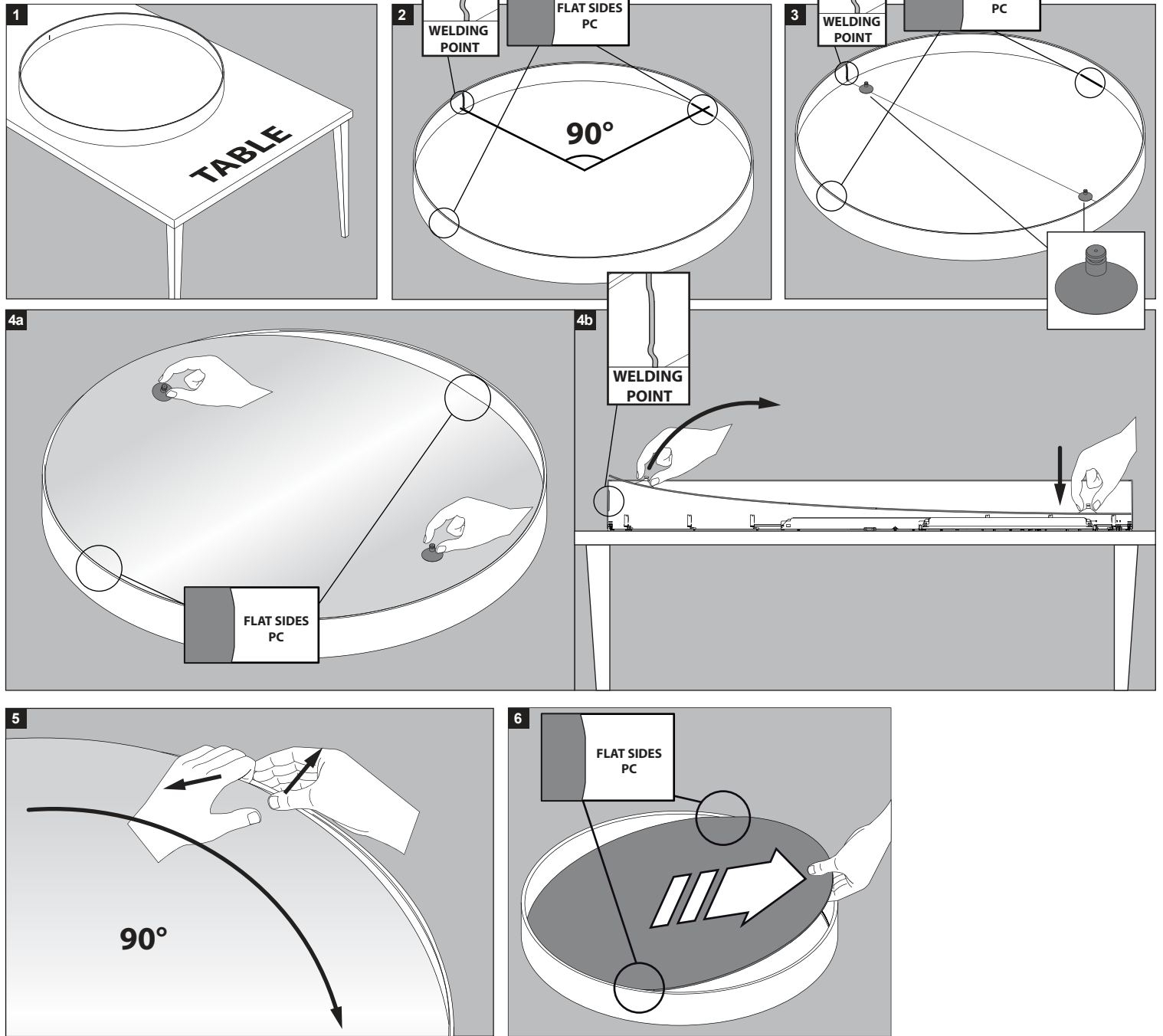

HOW TO PUT THE LENS BACK?

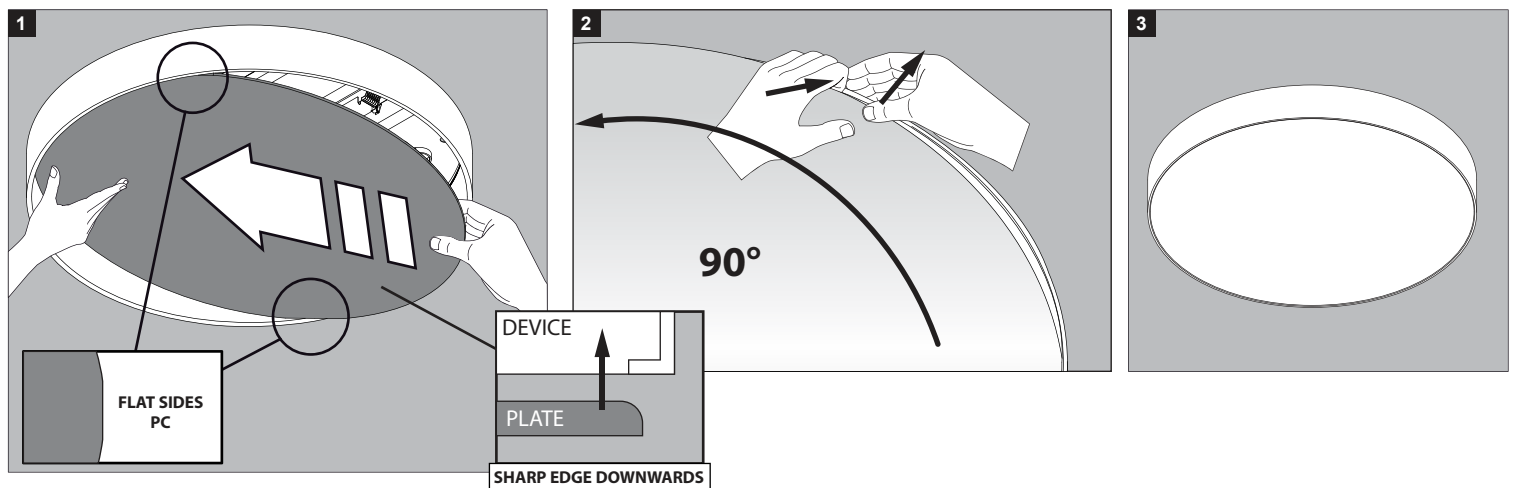

 Voorzien van aardingsaansluiting
 Avec mise à la terre
 Ausgerüstet mit Erdungsanschluss
 Provided with grounding
 Con la toma de tierra
 Con presa a terra

 **IP20** Beschermd tegen vaste voorwerpen die groter zijn dan 12 mm
 Protégé contre les objets solides de plus de 12 mm
 Geschützt gegen Festkörper größer als 12 mm
 Protected against solid objects greater than 12 mm
 Protegido contra objetos sólidos superiores a 12 mm
 Protetto contro oggetti solidi più grandi di 12 mm

 This product contains a light source of energy efficiency class D
 本产品包含能效等级为 D 的光源
 Этот артикул содержит источник света с энергоэффективностью класса D
 يحتوي هذا المنتج على مصدر ضوء ذو كفاءة الطاقة D
 Dit product bevat een verlichtingsbron van energie-efficiëntieklasse D
 Ce produit contient une source d'éclairage de classe d'efficacité énergétique D
 Dieses Produkt enthält eine Lichtquelle der Energieeffizienzklasse D
 Este producto contiene una fuente de iluminación de clase de eficiencia energética D
 Questo prodotto contiene una fonte di illuminazione in classe di efficienza energetica D

Replaceable (LED only) light source and control gear by a professional
 (仅针对LED)光源及其控制设备只能由专业人员更换
 (для СВЕТОДИОДНЫХ светильников) замена источника света и блока питания может быть произведена только квалифицированным специалистом
 مصدر الضوء (إيد فقط) ومعدات التحكم قابلين للتغيير بإشراف الفني المتخصص
 Verlichtingsbron (enkel LED) en voorschakelapparaat kan enkel vervangen worden door een professional
 La source d'éclairage (uniquement LED) et le ballast ne peut être remplacé que par un professionnel
 Die Lichtquelle (nur LED) und Vorschaltgerät kann nur von einem Fachmann ausgetauscht werden
 La fuente de iluminación (solo LED) solo puede ser reemplazada por un profesional
 La sorgente luminosa (LED) e l'alimentatore possono essere sostituiti solo da un professionista.

The luminaire should be positioned so that prolonged staring into the luminaire at a distance closer than 0,284 m is not expected.
 照明设备安装的位置应避免距离短于 0,284 厘米的凝视
 Светильник должен быть расположен таким образом, чтобы не предполагался длительный прямой зрительный контакт со светильником с расстояния ближе 0,284м.
 يجب وضع للمصباح بحيث يحذق لفترة طويلة في المصباح عند المسافة أقرب من 0,284 م غير متوقع.
 Het toestel dient op een plaats te worden gemonteerd van waaruit langdurig staren in de lichtbron, vanop een afstand van 0,284m, vermeden wordt.
 Le luminaire doit être positionné afin d'éviter tous contacts prolongé visuels à moins de 0,284m.
 Die leuchte soll so montiert werden, dass ein längerer direkter Augekontakt mit der LED aus einer Distanz von weniger als 0,284m vermieden wird.
 Per evitare il rischio di danni alla vista, l'apparecchio deve essere montato in modo che non si possa guardare direttamente la sorgente luminosa da una distanza inferiore a 0,284m per un tempo prolungato.
 La luminaria se tiene que instalar de tal forma que no se pueda mirar fijamente la fuente de luz por un tiempo prolongado a una distancia de menos de 0,284m, ya que pueda dañar los ojos

MORE INFO PHOTOBIOLOGICAL SAFETY
https://www.deltalight.com/downloads/Photobiological_safety.pdf



 SCAN ME